

**PRODUCT  
SPECIFICATIONS**

**ANCHOR PATTERN 1**  
96 cm - 1.2 m  
(3) 3/4" Anchors  
Equally Spaced on 6.80" Bolt Circle

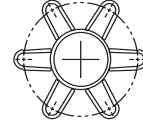

**ANCHOR PATTERN 2**  
1.8 m  
(6) 3/4" Anchors  
Equally Spaced on 8.50" Bolt Circle

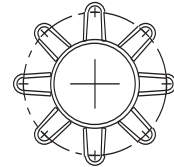

**ANCHOR PATTERN 3**  
2.4 m  
(8) 3/4" Anchors  
Equally Spaced on 10.68" Bolt Circle

Each model includes  
an anchor bolt kit.

## King Post Mounts

The Andrew Corporation King Post Mounts are specifically designed for our 96 cm, 1.2 m, 1.8 m and 2.4 m reflectors. Mechanically tested and field proven, these fully adjustable mounts exceed the performance requirements of demanding commercial applications. When assembled and mounted according to the installation instructions provided, these King Post Mounts are engineered to withstand 125 mph winds.

For accuracy and ease of assembly, each mount is accompanied with an anchor pattern template and all necessary installation hardware.

Andrew Corporation King Post Mounts and hardware are constructed from heavy-gauge steel and are hot-dip galvanized for maximum environmental protection.

MODEL	ANTENNA SIZE	KING POST O.D.	ANCHORS AND PATTERN NUMBER	ANCHOR BOLT CIRCLE DIAMETER
610012901	96 cm-1.2 m	2.88" (73 mm)	3 ANCHORS, PATTERN #1	6.80"
610013001	1.8 m	4.50" (114 mm)	6 ANCHORS, PATTERN #2	8.50"
610013101	2.4 m	6.635" (168 mm)	8 ANCHORS, PATTERN #3	10.68"

**96 CM, 1.2 M, 1.8 M AND 2.4 M KING POST MOUNTS**

**Elevation Diagram**

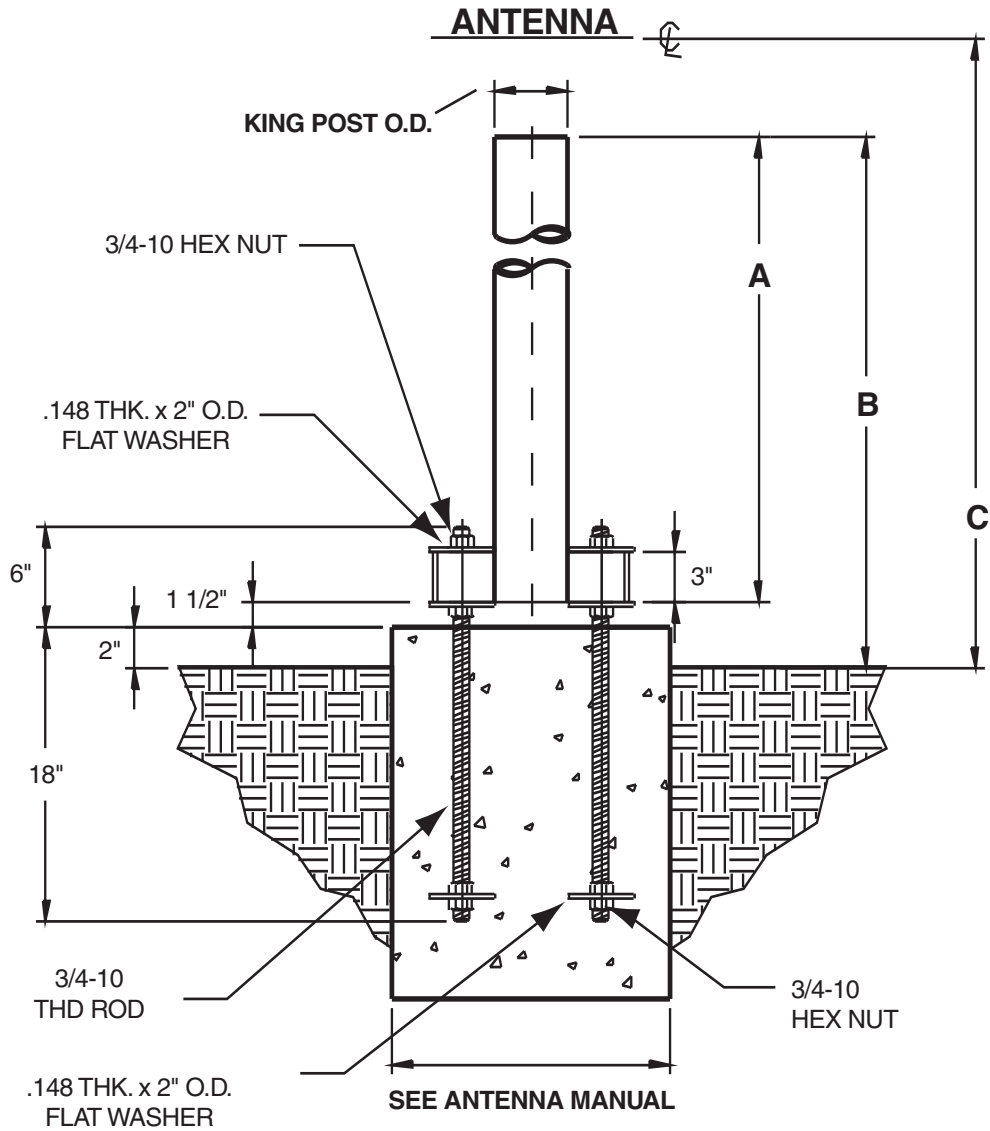

MODEL	DIMENSIONS			ALLOWABLE WINDSPEED EXPOSURE B	ALLOWABLE WIND SPEED EXPOSURE C
	A	B	C		
610012901	30.0"	33.5"	40.9"	125 MPH	118 MPH
610013001	46.5"	50.0"	55.5"	125 MPH	116 MPH
610013101	60.0"	63.5"	69.5"	125 MPH	107 MPH



Andrew Corporation  
10500 W. 153rd Street  
Orland Park, IL 60462 USA

One Company. A World of Solutions.

Customer Support Center  
From North America  
Telephone: 1-800-255-1479  
Fax: 1-800-349-5444  
satcom@andrew.com

International  
Telephone: +1-708-873-2307  
Fax: +1-708-349-5444

Internet: www.andrew.com

All designs, specifications and availabilities of products and services presented in this bulletin are subject to change without notice.

Bulletin PA-100541-EN (6/05)  
© 2005 Andrew Corporation, Orland Park, IL 60462 USA